



ENGINE - VARIABLE HORSEPOWER (VHP)

Model	NEF N67 F4HGE614M*V003 Tier 4 Final / Stage V certified
Type	4-stroke, turbocharged, air cooled, electronically controlled, no EGR
Cylinders	6-cylinder in-line
Displacement	6.7 L
Fuel	Diesel
Fuel injection	High pressure electronic common rail
Horsepower @ 2100 RPM – ISO 14396/ECE R120: Net	137/154 hp (102/115 kW)
Maximum torque @ 1400 RPM:	535 ft-lb (725 N-m)

DRIVETRAIN

Rear axle	Graziano, planetary	
Differential	Hydraulic lock, operator controlled	
Inboard brakes	Wet disc	
Number of discs/brake	5	
Brake surface area	2,225 in ² (14 336 cm ²)	
Tandems:		
Type	Welded plate	
Oscillation	15° each way	
Front axle	High strength, welded steel	
Oscillation	15° each direction	
Wheel lean	21.75° each direction	
Tires – standard	405/70 R20 SPT9 Dunlop	
Rims	1-piece 13 in x 20 in (330.2 mm x 508 mm)	
Transmission type:	Direct drive countershaft Powershift w/ electronic shift control and inching pedal	
Pump flow @ 2000 RPM	22.4 gpm (85 L/min)	
Sump	Integral	
Speeds	6 forward/3 reverse	
Shifting	Single lever, bump style automatic electronic control	
Diagnostics	On-board	
Speeds:	MECHANICAL	EH
Forward:	mph (km/h)	mph (km/h)
1st	3.3 (5.4)	3.4 (5.4)
2nd	5.2 (8.3)	5.3 (8.5)
3rd	7.8 (12.6)	8.1 (13.0)
4th	11.9 (19.2)	12.4 (19.9)
5th	17.3 (27.9)	17.8 (28.7)
6th	24.8 (39.9)	26.0 (41.9)
Reverse:	mph (km/h)	mph (km/h)
1st	3.5 (5.7)	3.5 (5.7)
2nd	8.3 (13.3)	8.3 (13.3)
3rd	18.1 (29.2)	18.1 (29.2)

ELECTRICAL

Voltage	24 Volts, negative ground
Alternator	90 amp
Batteries	2 – Low-maintenance 800 CCA – 100 Ah (20 hr rate)
Work lights:	
Headlights	– 2; Turn signals, front/rear;
Stop/tail	– 2; Rear mounted floods – 2;
Front mounted floods	– 2.
Backup alarm	Standard

OPERATOR ENVIRONMENT

ROPS/FOPS certified (SAE J231, ISO 3449) air conditioned and heated low profile pressurized cab; Openable front window; 8" always active touch-screen display upon key on with machine usage reports, fault codes and alarms, fuel consumption and maintenance report; Dual side cab access with fully swinging doors, tinted safety glasses, front and rear sunshield, openable front windows; Adjustable operator's console and controls, steering wheel, indicator lights; Air suspension seat with 3 in (76 mm) retractable seat belt and adjustable armrests; Dome light; Inside and outside rearview mirrors; Cup holder; Storage tray; 12-volt outlet; AM/FM radio; Sound suppression; Steps – left/right; Front and rear windshield wiper; Front and rear windshield washer; Rear window defroster; Coat hook; Storage box left and right; Hand operated throttle dial.

OPERATING WEIGHT

W/ 11 ft (3.35 m) moldboard, 405/70R20 tires, front counterweight, rear ripper – 5 teeth, 175 lb (79 kg) operator and full fuel:

836D	26,495 lb (12 018 kg)
836D AWD	27,318 lb (12 318 kg)
Weight, front axle:	
836D	6,226 lb (2 824 kg)
836D AWD	6,446 lb (2 924 kg)
Weight, rear axle:	
836D	20,269 lb (9 194 kg)
836D AWD	20,710 lb (9 394 kg)
Blade pressure:	
836D	10,736 lb (4 870 kg)
836D AWD	11,003 lb (4 991 kg)

HYDRAULICS

System design	Closed center, load sensing
Hydraulic pump	Load sensing piston pump, variable displacement, pressure and flow compensated
Rated flow @ 2100 RPM	
836D EH	34.8 gpm (132.3 L/min)
836D MECHANICAL	25 gpm (94.5 L/min)
Control valve	10 section
Side shift and pitch	Hydraulic
Saddle	5 positions
Diagnostic quick couplers	8

SERVICE CAPACITIES

Engine	3.3 gal (12.5 L)
Fuel	73.4 gal (278 L)
Transmission	5.5 gal (21 L)
Radiator	8.45 gal (32 L)
Hydraulic reservoir	18.5 gal (70 L)
Hydraulic system:	
836D	48.9 gal (185 L)
836D AWD	48.9 gal (185 L)
Circle gearbox	0.66 gal (2.5 L)
Rear axle center	8.2 gal (31 L)
Tandem case, each	15.9 gal (60 L)

OTHER SPECIFICATIONS

Steering:	
836D MECH	Open Center, Reaction, without LS
836D EH	Closed center, Reaction, LS, dual displacement
Turns – lock-to-lock	7
Pump capacity @ 2100 engine RPM:	5.8 gpm (22 L/min)
Relief pressure	2,176 psi (150 bar) Integral w/ priority valve
Cylinder – 2:	1.75 in bore x 9.84 in stroke x 0.87 in rod dia. (44.5 mm x 250.0 mm x 22.2 mm)
Supplemental steering	Integral
Articulation:	
Type	Hydraulic actuated, no external stop
Range	28° left/right
Controls	Hydraulic

MAINFRAME

Type	All welded box
Front section:	
Size	10.7 in x 10.7 in (270 mm x 270 mm)
Weight – each side	61.9 lb-ft (92.1 kg/m)
Rear section:	
Size	8.7 in x 2.4 in (220 mm x 60 mm)
Weight – each side	69.6 lb-ft (103.6 kg/m)

DRAWBAR

Type:	"A" frame welded construction with center mounted circle turn motor
Ball and circle	Shim adjustable

MOLDBOARD

Type	High-carbon steel
Shape	Involute curve
Length	11 ft 0 in (3 355 mm)
Height	23.6 in (526 mm)
Thickness	0.59 in (15 mm)
End bits	2, interchangeable
Blade pitch positions:	
Normal pitch	47°
Minimum pitch	36°
Maximum pitch	86°
Blade shift:	
Right	19.33 in (491 mm)
Left	27.87 in (708 mm)
Max. bank cutting angle:	
Right	117°
Left	76°
Max. ground penetration	17.95 in (456 mm)
Max. lift above ground	15.51 in (394 mm)

CIRCLE

Type	Welded construction
Diameter:	
Max. outside	41.3 in (1 050 mm)
Vertical member	63.0 in (1 600 mm)
Rotation	360°
Speed	1.86 RPM (11.2°/second)
Drive	Hydraulic motor
Type	Roller geroter
Displacement	4.9 in ³ /Rev. (0.25 L/Rev.)
Rated hydraulic flow	19.8 gpm (75 L/min)

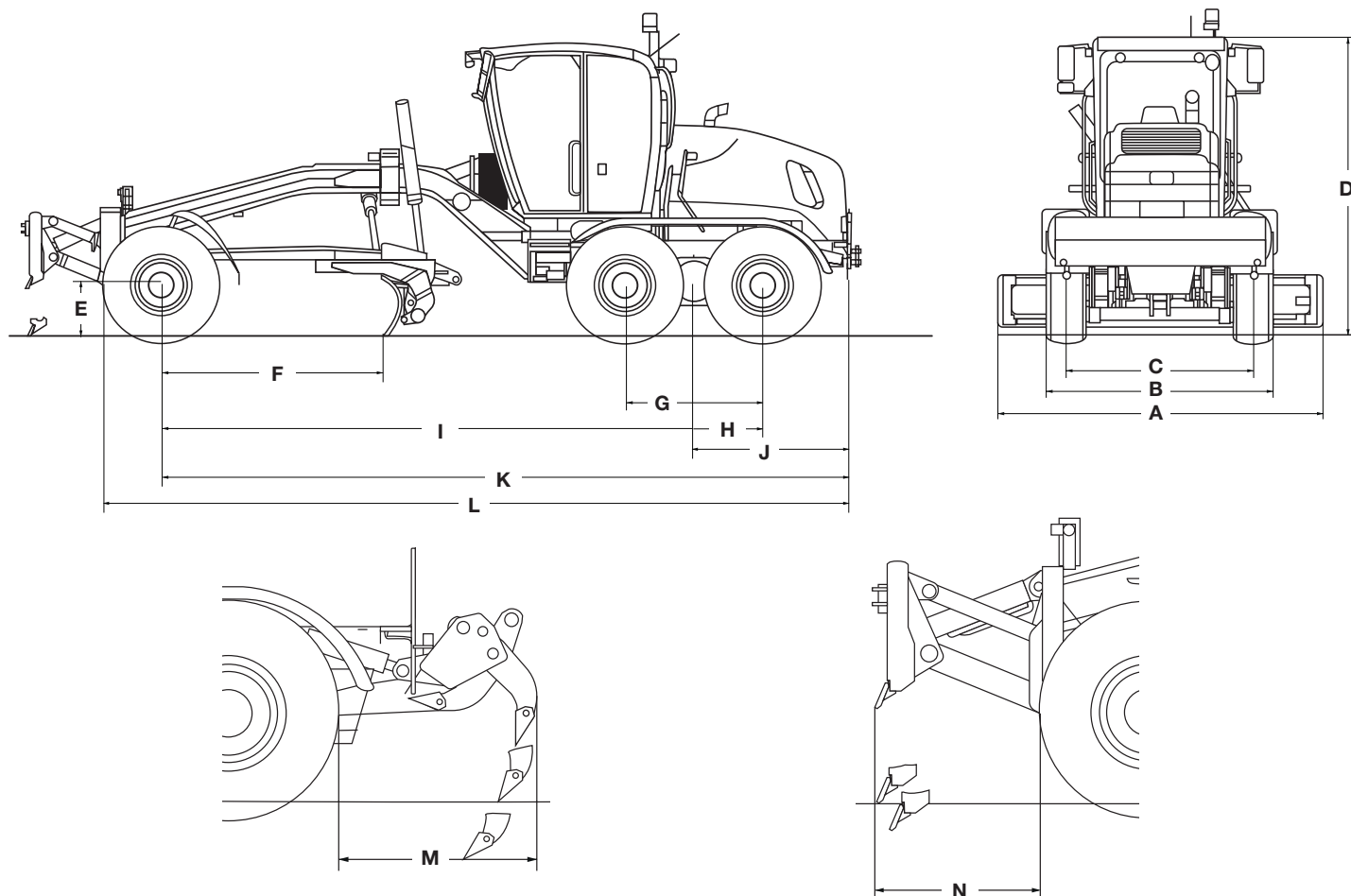

Line drawings are for illustrative purpose only and may not be exact representation of unit.

DIMENSIONS	836D	836D AWD
A. Blade width	11 ft 0 in (3 355 mm)	11 ft 0 in (3 355 mm)
B. Distance between outside edges of tires	7 ft 8 in (2 326 mm)	7 ft 7 in (2 303 mm)
C. Wheel tread – rim 13 x 20 – one piece rim	6 ft 4 in (1 923 mm)	6 ft 3 in (1 900 mm)
D. Height to top of cab – low profile	10 ft 1 in (3 060 mm)	10 ft 1 in (3 060 mm)
E. Tire radius – when static	1 ft 7 in (487 mm)	1 ft 7 in (487 mm)
F. Blade base	6 ft 6 in (1 981 mm)	6 ft 6 in (1 981 mm)
G. Distance between tandem axles	4 ft 1 in (1 241 mm)	4 ft 1 in (1 241 mm)
H. Distance between tandem center and wheel	2 ft 0 in (621 mm)	2 ft 0 in (621 mm)
I. Wheelbase	17 ft 7 in (5 351 mm)	17 ft 7 in (5 351 mm)
J. Distance between tandem center and rear end of machine	5 ft 2 in (1 585 mm)	5 ft 2 in (1 585 mm)
K. Distance between front axle and rear end of machine	22 ft 9 in (6 936 mm)	22 ft 9 in (6 936 mm)
L. Overall length – without ripper or front attachment	27 ft 4 in (8 372 mm)	27 ft 4 in (8 372 mm)
M. Distance between rear tires and rear ripper	5 ft 4 in (1 625 mm)	5 ft 4 in (1 625 mm)
N. Distance between front tires and front dozer blade	4 ft 8 in (1 424 mm)	4 ft 8 in (1 424 mm)
Outside tire turning radius	21 ft 8 in (6 600 mm)	22 ft 4 in (6 800 mm)
Ground clearance – rear axle	12.2 in (310 mm)	12.2 in (310 mm)
Ground clearance – front axle	19.1 in (485 mm)	19.1 in (485 mm)

NOTE: All units equipped with 405/70R20 tires, ROPS cab with heater and A/C, std. battery, full fuel, 175 lb (79 kg) operator. Specifications per ISO 7134.

STANDARD EQUIPMENT

ENGINE

F4HGE614M*V003 NEF 6 cyl. CR TAA 4V turbocharged diesel
Tier 4 Final / Stage V Certified
Temperature controlled cooling fan
SCR only exhaust gas after-treatment, no EGR
Charge air cooler
Air intake grid heater
Common rail electronic fuel injection
Hydraulic driven cooling fan
Auto idle
Cold start up to 9.4F (-23°C)
Air cleaner/pre-cleaner with scavenge line and safety element
Variable fan speed

DRIVETRAIN

Hydraulic differential lock
Immobilization disc brake on transmission
Powershift transmission with 6 Forward and 3 Reverse speeds with integrated torque converter
Hydraulic dual circuit brake system
Hydrostatic front wheel drive D.C.V.
Electronic Drive Control Volume and hydraulic differential – FWD version only
Internal gearing:
Covered, Backlash-free and maintenance free slewing ring operation on 360°
Hydrostatic power steering
Circle drive without overload clutch
Rear axle with automatic/manual gear shifting
Transmission with automatic/manual gear shifting

HYDRAULICS

Load sensing hydraulic system
Controls for all functions
10 section control valve
Hydraulic moldboard side shift and pitch
5-position saddle
11 ft x 20.7 in (3 355 x 526 mm) moldboard
8 hydraulic diagnostic quick couplers
Front and rear piping for hydraulic attachment
Moldboard support no scarifier
Oscillating front axle with hydraulic lean adjustment
Oscillating tandem axle with automatic no-spin differential
Hydraulic circle turn – 360°
Hydraulic system lock valves for blade lift, blade shift, front wheel lean, blade pitch, articulation and special equipment
Lock valve lift cylinder blade

TIRES

405/70 R20 SPT9
TPMS - tire pressure monitoring system

INSTRUMENTS

Digital displays/Gauges:
Fuel level; Engine coolant temperature; Transmission oil temperature; Hydraulic oil temperature.
Monitor Functions:
Hour meter; Automatic trans indication; DEF/Ad blue level indication; Floating – if activated; FWD aggressive mode; Error prompt; Park brake message; Clutch engagement status; Vehicle moving – yes/no; Engine speed; Travel speed; Current gear selection; FNR indication; Clock; Trip computer; Fuel consumption; Fuel level percentage; Oil pressure; Coolant temperature; Engine oil temperature; Transmission oil temperature; Hydraulic oil temperature; Turbocharger air temperature; Differential lock indicator; Gear selection indicator; Engine diagnostics; Transmission diagnostics; Keypad diagnostics; UCM diagnostics; Speed limit module; Support for different severities – White/Yellow/Red; System voltage; Error reporting; Warning prompts; Indicator warning lamps – main warning, parking brake, low brake pressure, low steering pressure, Pre-glow, high beams, turn signals, hazard lights, low fuel

ELECTRICAL

2 – Heavy-duty batteries – 800 CCA
Battery main switch
Electronic Systems Monitor
Horn
Alternator – 90 amp
Headlights
2 – Turn signals front
2 – Tail lights with turn signals, brake lights
Flood lights – cab mounted
Rear view camera
2 – Front mounted working lights
2 – Floodlights at moldboard
2 – Floodlights at articulation
2 – Floodlights rear
Backup alarm

OTHER

Front counterweight
Rear counterweight
Front fender with hinged mudflaps
Rear fender
Wheel chocks x 2
Standard tooling
Drive Shaft Maintenance Free
Rear Ripper Maintenance Free
Dozer Maintenance Free
Beacon
Toolbox with tools

TELEMATICS

CASE SiteWatch™ Telematics – includes hardware and a 5-yr Advanced data subscription for 2-way communication

OPTIONAL EQUIPMENT

MOLDBOARDS

8 ft x 20.7 in (2 440 x 526 mm)
10 ft x 20.7 in (3 050 x 526 mm)
Extensions – 2 ft (610 mm)
Front Float Control
Moldboard Float Control
Lift cylinder/side shift accumulators
Lift cylinder accumulators
Moldboard with overload clutch
Moldboard side plates left/right

HYDRAULICS

Rear ripper hydraulic predisposition
Environment friendly hydraulic oil - Panolin

FLOAT TIRES

420/75 R20 XMCL TL Michelin
455/70 R20 SPT9 Dunlop
405/70 R24 SPT9 Dunlop

ATTACHMENTS

Front pull hook
Front counterweight – 1,124 lb (510 kg)
Rear counterweight – 330.7 lb (150 kg)
Front dozer blade
Moldboard scarifier
Moldboard ripper
Front push plate
Front support and lift cylinder
Rear ripper with 3 or 5 teeth with
or without protective device

CaseCE.com

©2024 CNH Industrial America LLC. All rights reserved. CASE is a trademark registered in the United States and many other countries, owned by or licensed to CNH Industrial N.V., its subsidiaries or affiliates. CNH Industrial Capital is a trademark in the United States and many other countries, owned by or licensed to CNH Industrial N.V., its subsidiaries or affiliates. Printed in U.S.A. Contains 10% post-consumer fiber.

IMPORTANT: CASE Construction Equipment Inc. reserves the right to change these specifications without notice and without incurring any obligation relating to such change. Availability of some models and equipment builds vary according to the country in which the equipment is used. The illustrations and text may include optional equipment and accessories and may not include all standard equipment. Your CASE dealer/distributor will be able to give you details of the products and their specifications available in your area.



CASE Construction Equipment is biodiesel-friendly. NOTE: All engines meet current EPA emissions regulations. All specifications are stated in accordance with SAE Standards or Recommended Practices, where applicable.



Always read the Operator's Manual before operating any equipment. Inspect equipment before using it, and be sure it is operating properly. Follow the product safety signs and use any safety features provided.