

HITACHI

COMPACT CONSTRUCTION HYDRAULIC EXCAVATOR ZX75US-7

Reliable Solutions



Gross Power : 64 HP (47.5 kW)
Operating Weight : 18,600 lbs (8,418 kg)
Max Dig Reach : 22 ft 6 in (6.87 m)
Max Dig Depth : 15 ft 3 in (4.65 m)
Model Code : ZX75US-7

ZAXIS 75US

Hitachi Construction Machinery Group

LANDCROS

Japanese Excellence—Reliable Solutions

A Legacy of Confidence

Known worldwide, Hitachi Construction Machinery has helped generations of builders, doers, and earth-movers accomplish their goals. Hitachi Construction Machinery Americas is the source for all U.S. and Latin American operations hoping to improve productivity and reduce costs — all while building our shared future.

Pioneering Progress Together

From dedicated Rental and Used machines business to servicing, parts sales, and remote diagnostic support, Hitachi Construction Machinery Americas has the know-how and desire to establish productive working partnerships across the region. A network of independent, local dealers providing sales and service support are at the ready, waiting to begin work on the next phase of your legacy.



Welcome to

Hitachi Construction

Endless Ambition

All of our machines have been built at state-of-the-art Hitachi Construction Machinery production facilities in Japan, after incorporating the unique needs of our North American customers. Designed for the toughest terrains, harshest environments and most intricate projects, we believe there is no job that couldn't make use of our machine.

Unwavering Dependability

Our dedication to reliability parallels our commitment for your comfort. Safety is non-negotiable; our machines adhere to the highest standards, ensuring your team's well-being. Count on Hitachi Construction Machinery Americas for peace of mind to ensure every team member returns home safely after a hard day's work.



Machinery Americas



Command with **QUALITY**

Hitachi Construction Machinery Americas is proud to introduce ZAXIS-7, the next evolution of excavators that proudly wear our name.

At job sites across the world, our partners depend on the latest Hitachi Construction Machinery Americas equipment for increased productivity, improved operator comfort, efficient maintenance needs and innovative safety features proven to keep workers safe.

This brochure is a guide for fleet owners as well as day-to-day operators of this equipment who are hoping to save time, money, to dream big — and build bigger.

Building on decades of quality engineering, Hitachi Construction Machinery Americas presents the latest in its ZAXIS-7 lineup, the ZX75US-7 excavator.





TABLE OF CONTENTS

- 02** Who We Are
- 04** Introduction
- 06** Machine Highlights
- 08** Performance
- 10** Applications
- 12** Inside the Cab
- 14** Service & Maintenance
- 16** Safety
- 18** Specifications

Huge **POTENTIAL**

Able to work where other excavators can't, the new ZX75US-7 takes job site productivity to new levels owing to its compact exterior and outsized capabilities as an excavator. Figure a brand-new, larger cab, lower operating costs, and time-saving features to help get the most use out of this truly multifunctional machine.

For the first time, multiple attachment settings can be saved for later use, reducing the time needed to swap tools. Power, smoothness and ease of operation are as operators expect from Hitachi Construction Machinery Americas equipment.

More capable than ever, the ZX75US-7 is the only compact machine built with the same quality and attention-to-detail as our larger excavators.

New Compact Design

Ultra-short-tail swing radius on the ZX75US-7 allows unparalleled access to confined spaces, without compromising on a larger cab space, more work-ready features, and easier maintenance access.

Next Generation Technology

Using the in-cab 8" anti-glare LCD monitor, access a 270° camera system, 2 working modes, and up to 16 attachment presets for plug and play versatility.

Quiet & Capable Engine

Powerful Yanmar diesel engine with up to 211 lbf (285 Nm) of torque.

Increased Durability

Stout undercarriage with enhanced frame protection and optional heavy-duty cab guard.

Quality Materials

With a durable build and premium cab materials, this compact excavator is every inch a Hitachi Construction Machinery Americas workhorse.





First-Class Cab Comfort

More legroom, headroom, and air suspension seat, and dual adjustable seat and console frontward/backward
Powerful, dust resistant AC & heating system.



Available Angle Blade

Available Available heavy duty angle blade specification with blade float control for grading operations dramatically increases the machine's possible uses.



Service & Maintenance

With ConSite Air, ConSite Oil (optional), and simplified daily maintenance routines, ZX75US-7 is made to deliver more uptime for busy operators.



Gross Power : 64 HP (47.5 kW)
Operating Weight : 18,600 lbs (8,418 kg)
Max Dig Reach : 22 ft 6 in (6.87 m)
Max Dig Depth : 15 ft 3 in (4.65 m)

PRODUCTIVE Power

A compact size doesn't mean reduced performance. Accomplish more with the unparalleled torque and precision of the ZX75US-7, powered by a stout Yanmar engine up to 63.7 HP (47.5 kW). Made to work where other machines can't, with available dust-reducing filters and precise control over up to 16 attachments.

More Digging Force

Adding a turbocharger and improving hydraulic performance have led to significant improvements in digging force, compared with previous Hitachi Construction Machinery Americas excavators.



Standard Work Modes

Two operator work modes (ECO, Power) best match available power to job site conditions.

Remarkable Stability

Improved stability in both front and lateral loading. An available, optional heavier counterweight can provide increased performance.

Smart Engine Management

Yanmar engine with built-in modes like an auto idle system with auto shutdown control to enhance fuel efficiency.

Full Operator Control

Settings monitor allows operators to save attachment presets for a range of jobs, from trench work to precise demolitions.

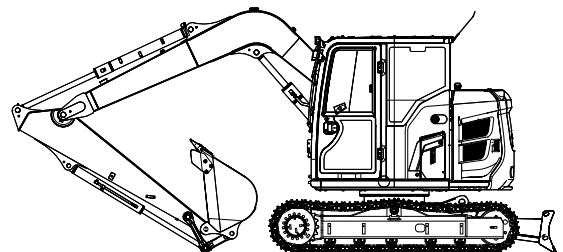

HIGHLY MOBILE



MORE
VERSATILITY
and Ultimate
Operator Comfort

Excavator

TEAM Player

With the unique needs of confined spaces and owner / operators in mind, the **ZX75US-7** has everything needed to accelerate productivity. Excellent for job sites where precision and versatility are needed. Attachment settings can be saved for future use. Get it done on budget with lower total cost of ownership than our previous compact excavators.





I believe the ZX75US-7 Premium Compact Excavators are game changers in our market because they are the Swiss Army Knives on job sites for their performance and versatility. These machines are primed to connect to numerous multifunction attachments with their customizable Auxiliary Flow settings, an added Assist adjustable flow option, and separate Quick Attachment functions. **While they certainly have the power to dig, they can now do a whole lot more.**



Jim Ramsdail
Hitachi Construction Machinery Americas
Excavator Service Trainer





1

2

3

4

5

16

13

15

6

14

7

8

9

10

HITACHI

12

11



CONFIDENT Controls

A larger cab built with operators at heart: more interior space, less noise, a panoramic view for operators, and one-touch adjustable air suspension seat synchronized to move with the console. ROPS and FOPS certified cab.

- 1 Increased sweeping area of parallel link wiper** enhances visibility in difficult working conditions.
- 2 Air conditioning and audio** are easily controlled via the monitor.
- 3 Low-reflective color 8" LCD monitor** is easy to view and navigate.
- 4 USB socket and smartphone holder** helps you stay connected.
- 5 Drinks holder** is easy to detach for cleaning.
- 6 Additional joystick controls** for effortless operation.
- 7 Ergonomic design** gives you convenient access to controls.
- 8 Bluetooth®** for hands-free calls.
- 9 Multifunctional control panel** makes operation easier.
- 10 Improved sound isolation** makes this one of the quietest cabs in the market.
- 11 User-friendly storage space** keeps your workspace tidy and clutter-free.
- 12 Coat hooks** take care of your personal belongings.
- 13 One-touch adjustment lever for console** so you can work comfortably in the optimum position.
- 14 Integrated console and seat suspension** gives a greater sense of control and helps to reduce fatigue.
- 15 Increased legroom** creates a more spacious cab.
- 16 Optimal pedal layout** helps to reduce fatigue.



SERVICE That Sticks

Protect your investment with proactive support services. Hitachi Construction Machinery Americas' distribution network is dedicated to optimal uptime of our, with dedicated support team and dealers. Ask about how ConSite Oil and ConSite Air technology further increases uptime — a Hitachi Construction Machinery exclusive.

ConSite
Consolidated Solution for Construction Sites



NO HASSLE Maintenance

From up-to-the-second remote management with ConSite to the leading Hitachi Construction Machinery Americas Certified Remanufactured Components program, maintenance support is second-to-none. Identify problems before they start and supercharge productivity with our behind-the-scenes data platform that allows for remote fleet diagnostic access.



360° SAFETY

Innovative, standard safety features are core to maintaining an incident-free jobsite. From a standard AERIAL ANGLE camera system to a full suite of operator tools to ensure safety always comes first.

AERIAL ANGLE Cameras

Peripheral vision camera system provides a wide 270-degree bird's-eye view of the machine's immediate environment.

Unmatched Visibility

See and be seen: LED work lights, large reflective strips, improved windshield wiper and opening front & upper windows ensure visibility in all conditions.

Cab Guards

Optional cab guarding increases operator protection in extreme and challenging environments.

2-Way Disconnect Switch

Safety feature that shuts down power without resetting communication functions for machine data and clock.

Hose Rupture Valves

Standard hydraulic hose rupture valves instantaneously prevent loads from shifting if a line becomes damaged.





SPECIFICATIONS

ZX75US-7

ENGINE	
Model	4TNV98CT
Type	4-cycle water-cooled, common rail direct injection exhaust turbo charger
Aspiration	Cooled EGR
Aftertreatment	Muffler filter
No. of cylinders	4
Rated power	
ISO 14396: 2002 gross	67.6 HP (50.4 kW) at 2,000 min ⁻¹
ISO 9249: 2007 net	63.7 HP (47.5 kW) at 2,000 min ⁻¹
Maximum torque	211 lbf (285.4 Nm) at 1,300 min ⁻¹
Piston displacement	202.5 cu.in. (3.318 L)
Bore and stroke	3.9" x 4.3" (98 mm x 110 mm)
Batteries	2 x 12 V / 60 Ah

HYDRAULIC SYSTEM				
Hydraulic Pumps				
Main pumps	3 variable displacement axial piston pumps			
Maximum oil flow	2 x 19 gal/min (72 L/min)			
	1 x 15 gal/min (56 L/min)			
Pilot pump	1 gear pump			
Maximum oil flow	5.0 gal/min (20.0 L/min)			
Hydraulic Motors				
Travel	2 variable displacement axial piston motors			
Swing	1 axial piston motor			
Relief Valve Settings				
Implement circuit	4,061 psi (28.0 MPa)			
Swing circuit	3,844 psi (26.5 MPa)			
Travel circuit	4,554 psi (31.4 MPa)			
Pilot circuit	566 psi (3.9 MPa)			
Hydraulic Cylinders				
ZX75US-7				
	Quantity	Bore	Rod diameter	Stroke
Boom	1	4.5" (115 mm)	2.8" (70 mm)	34.8" (885 mm)
Arm	1	3.7" (95 mm)	2.4" (60 mm)	35.4" (900 mm)
Bucket	1	3.3" (85 mm)	2.2" (55 mm)	28.7" (730 mm)
Blade	1	4.7" (120 mm)	2.8" (70 mm)	5.7" (145 mm)

UPPERSTRUCTURE	
Revolving Frame	
D-section frame for resistance to deformation	
Swing Device	
Axial piston motor with planetary reduction gear is bathed in oil. Swing circle is single-row. Swing parking brake is spring-set/hydraulic-released disc type.	
Swing speed	10.1 min ⁻¹
Swing torque	12,243 lbf (16.6 kNm)
Operator's Cab	
Independent spacious cab, 3' 4" (1,025 mm) wide by 5' 5" (1,654 mm) high, conforming to ISO* Standards. Reinforced glass windows on 4 sides for visibility. Front windows (upper and lower) can be opened. Reclining seat.	
* International Organization for Standardization	

UNDERCARRIAGE	
Tracks	
Tractor-type undercarriage. Welded track frame using selected materials. Side frame welded to track frame	
Numbers of Rollers and Shoes on Each Side	
Upper rollers	1
Lower rollers	5
Track shoes	40
Travel Device	
Each track driven by 2-speed axial piston motor. Parking brake is spring-set/hydraulic-released disc type. Automatic transmission system: High-Low.	
Travel speeds	High: 0 to 3.1 mph (0 to 5.0 km/h)
	Low: 0 to 1.9 mph (0 to 3.1 km/h)
Maximum traction force	14,660 lbf (65.2 kN)
Gradeability	70% (35 degrees) continuous

SERVICE REFILL CAPACITIES	
Fuel tank	33.0 gal (125.0 L)
Engine coolant	3.5 gal (13.1 L)
Engine oil	3.2 gal (12.3 L)
Travel device (each side)	0.3 gal (1.2 L)
Hydraulic system	26.4 gal (100.0 L)
Hydraulic oil tank	13.7 gal (52.0 L)

WEIGHTS AND GROUND PRESSURE

Operating Weight and Ground Pressure

Shoe type	Shoe width, in (mm)	Arm length, ft-in (m)	lb (kg)	psi (kPa)
Grouser shoe	18" (450)	6' 11" (2.12 m)	18,500 (8,380)	5.4 (37)
	24" (600)	6' 11" (2.12 m)	18,900 (8,554)	4.2 (29)
Rubber shoe	18" (450)	6' 11" (2.12 m)	18,300 (8,286)	5.4 (37)
Pad crawler shoe	18" (450)	6' 11" (2.12 m)	18,600 (8,418)	5.4 (37)

Including 0.37 yd³ (0.28 m³) (ISO 7451: 2007 heaped) bucket weight 465 lb (211 kg) and counterweight 2,568 lb (1,165 kg).

BUCKET AND ARM DIGGING FORCE

Unit: lbf (kN)

Arm length	6' 11" (2.12 m)
Bucket digging force* ISO 6015: 2006	12,926.5 (57.5)
Bucket digging force SAE: PCSA	11,262.9 (50.1)
Arm crowd force* ISO 6015: 2006	7,755.9 (34.5)
Arm crowd force SAE: PCSA	7,418.7 (33.0)

* At power boost

SPECIFICATIONS

ZX75US-7

WORKING RANGES

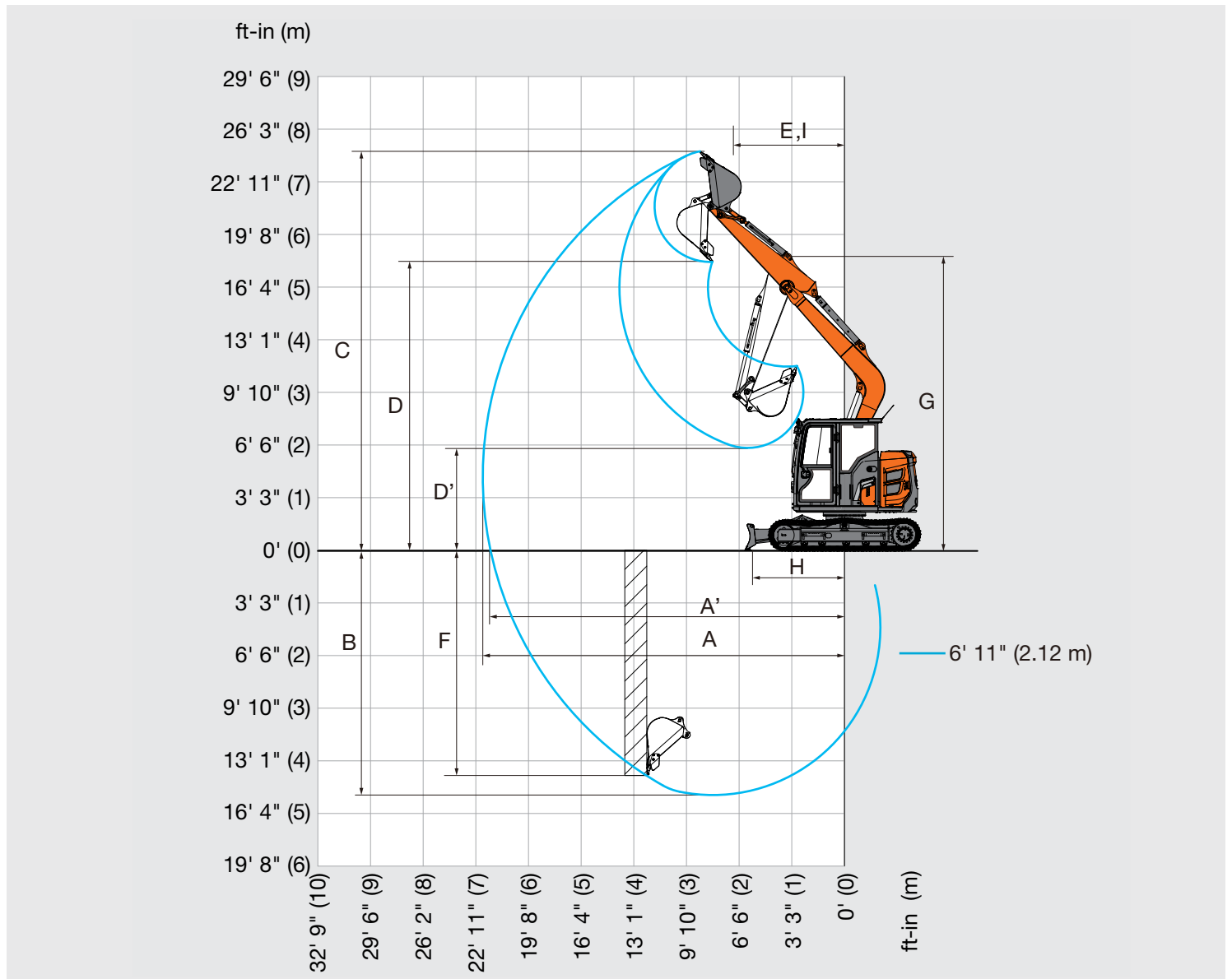

Unit: ft-in (mm)

	ZX75US-7
Arm length	6' 11" (2.12 m)
A Max. digging reach	22' 6" (6,870)
A' Max. digging reach (on ground)	22' 1" (6,720)
B Max. digging depth	15' 3" (4,650)
C Max. cutting height	24' 10" (7,580)
D Max. dumping height	18' 0" (5,480)
D' Min. dumping height	6' 5" (1,950)
E Min. swing radius	6' 11" (2,120)
F Max. vertical wall digging depth	14' 0" (4,260)
G Front height at Min. swing radius	18' 3" (5,570)
H Min. level crowding distance	5' 4" (1,630)
I Working radius at Min. swing radius (Max. boom-swing angle)	6' 11" (2,120)

Excluding track shoe lug

DIMENSIONS

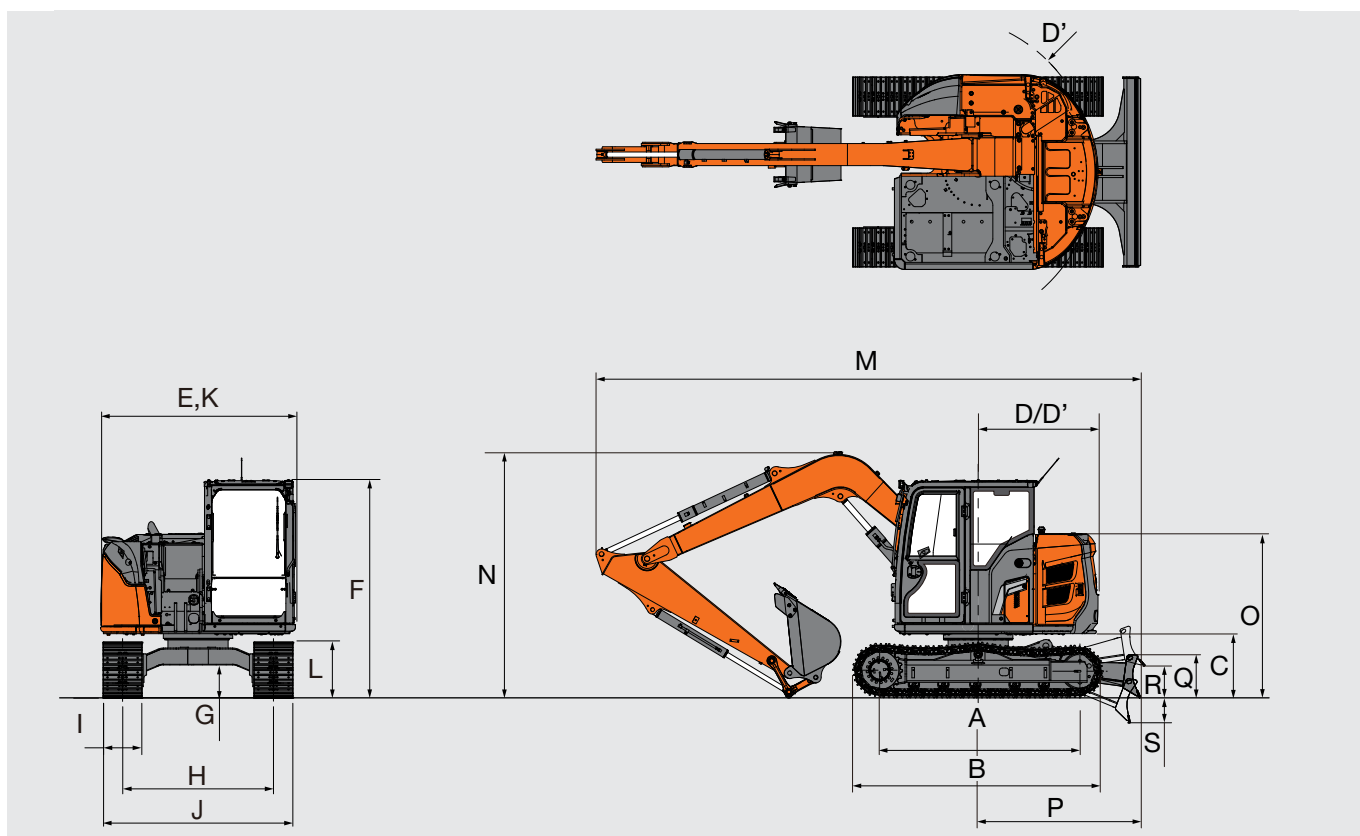

Unit: ft-in (mm)

	ZX75US-7
A Distance between tumblers	7' 6" (2,295)
B Undercarriage length	9' 6" (2,900)
C Counterweight clearance	2' 4" (720)
D Rear-end swing radius	4' 7" (1,390)
D' Rear-end length	4' 7" (1,390)
E Overall width of upperstructure	7' 5" (2,260)
F Overall height of cab	8' 3" (2,520)
G Min. ground clearance	1' 2" (360)
H Track gauge	5' 9" (1,750)
I Track shoe width	G 1' 6" (450)
J Undercarriage width	7' 3" (2,200)
K Overall width	7' 5" (2,260)
L Track height	2' 0" (610)
M Overall length with 6' 11" (2.12 m) arm	20' 9" (6,320)
N Overall height of boom with 6' 11" (2.12 m) arm	9' 5" (2,880)
O Engine cover-height	6' 2" (1,880)
P Distance between the front end of blade and the axis of rotation	6' 2" (1,890)
Q Blade height	1' 7" (472)
R Blade bottom highest position above ground	1' 2" (367)
S Blade bottom lowest position above ground	0' 11" (290)

* Excluding track shoe lug G: Grouser shoe

MACHINE CAPACITIES

ZX75US-7

- Notes:
1. Ratings are based on ISO 10567: 2007.
 2. Machine capacity does not exceed 75% of tipping load with the machine on firm, level ground or 87% full hydraulic capacity.
 3. The load point is the center-line of the bucket pivot mounting pin on the arm.
 4. *Indicates load limited by hydraulic capacity. 0 ft (0 m) = Ground. To determine lifting capacities, apply "Rating over-side or 360 degrees" machine capacities from table with "Blade above Ground" and deduct weight of installed attachment and quick hitch.
 5. Machine specifications are determined excluding the bucket.

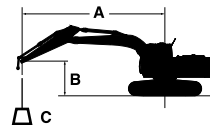

A: Load radius
B: Load point height
C: Machine capacity

For machine capacities, subtract installed attachment and quick hitch weight from machine capacities.

To determine lifting capacities, apply "Rating over-side or 360 degrees" machine capacities from the table and deduct weight of installed attachment and quick hitch. Optional feature may affect machine performance.

ZX75US-7, Blade above Ground

Rating over-front Rating over-side or 360 degrees Unit: lb (kg)

Conditions	Load point height (ft (m))	Load radius								At max. reach		
		5 ft (1.5 m)		10 ft (3.0 m)		15 ft (4.5 m)		20 ft (6.0 m)				ft-in (meter)
Boom 12' 2" (3.72 m)	20' (6.0)											
	15' (4.5)					3,440* (1,560)*	3,440* (1,560)*			3,030* (1,370)*	3,030* (1,370)*	15' 11" (4.84)
	10' (3.0)			4,200* (1,900)*	4,200* (1,900)*	3,710* (1,680)*	3,440 (1,560)			2,900* (1,310)*	2,470 (1,120)	18' 3" (5.56)
Arm 6' 11" (2.12 m)	5' (1.5)			6,490* (2,940)*	5,890 (2,670)	4,030 (1,820)	3,240 (1,470)			2,770 (1,250)	2,240 (1,010)	19' 1" (5.81)
Counterweight 2,568 lb (1,165 kg)	0 (Ground)			7,140 (3,240)	5,460 (2,470)	3,840 (1,740)	3,060 (1,390)			2,830 (1,280)	2,270 (1,030)	18' 6" (5.63)
Grouser shoe 18" (450 mm)	-5' (-1.5)	8,400* (3,810)*	8,400* (3,810)*	7,020 (3,180)	5,350 (2,430)	3,780 (1,710)	3,000 (1,360)			3,340 (1,510)	2,670 (1,210)	16' 4" (4.99)
	-10' (-3.0)	11,460* (5,200)*	11,460* (5,200)*	6,290* (2,850)*	5,510 (2,500)					4,880* (2,210)*	4,250 (1,920)	12' 0" (3.65)
	-15' (-4.5)											

ZX75US-7, Blade above Ground

Rating over-front Rating over-side or 360 degrees Unit: lb (kg)

Conditions	Load point height (ft (m))	Load radius								At max. reach		
		5 ft (1.5 m)		10 ft (3.0 m)		15 ft (4.5 m)		20 ft (6.0 m)				ft-in (meter)
Boom 12' 2" (3.72 m)	20' (6.0)											
	15' (4.5)					3,440* (1,560)*	3,440* (1,560)*			3,030* (1,370)*	3,030* (1,370)*	15' 11" (4.84)
	10' (3.0)			4,200* (1,900)*	4,200* (1,900)*	3,710* (1,680)*	3,710* (1,680)*			2,900* (1,310)*	2,820 (1,280)	18' 3" (5.56)
Arm 6' 11" (2.12 m)	5' (1.5)			6,490* (2,940)*	6,490 (2,940)	4,480* (2,030)*	3,690 (1,670)			3,030* (1,370)*	2,570 (1,160)	19' 1" (5.81)
Counterweight 3,516 lb (1,595 kg)	0 (Ground)			7,980* (3,620)*	6,230 (2,820)	4,360 (1,980)	3,510 (1,590)			3,230 (1,460)	2,620 (1,190)	18' 6" (5.63)
Grouser shoe 18" (450 mm)	-5' (-1.5)	8,400* (3,810)*	8,400* (3,810)*	7,970 (3,610)	6,120 (2,780)	4,300 (1,950)	3,450 (1,560)			3,810 (1,720)	3,070 (1,390)	16' 4" (4.99)
	-10' (-3.0)	11,460* (5,200)*	11,460* (5,200)*	6,290* (2,850)*	6,280 (2,850)					4,880* (2,210)*	4,850 (2,200)	12' 0" (3.65)
	-15' (-4.5)											

EQUIPMENT

ZX75US-7

●: Standard equipment ○: Optional equipment -: Not applicable

ENGINE	ZX75US-7
Aftertreatment device	●
Air cleaner double filters	●
Alternator 24 V – 60 A	●
Auto idle system	●
Auto shut-down control	●
Cartridge-type engine oil filter	●
Cartridge-type fuel main filter	●
ConSite OIL (sensor)*1	○
Dry-type air filter with evacuator valve (with air filter restriction indicator)	●
Electric fuel refilling pump	●
Engine oil drain coupler	●
Fan guard	●
Fuel cooler	●
Fuel pre-filter with water separator	●
Pre-cleaner	○
PWR / ECO mode control	●
Radiator reserve tank	●
Radiator, oil cooler with one touch type dust-proof indoor net	●
Radiator, oil cooler with one touch type cleaning interval extension net	○

HYDRAULIC SYSTEM	ZX75US-7
Auxiliary flow adjustment switching	○
Boom anti-drift valve	●
ConSite OIL (sensor)*1	○
Extra port for control valve	●
Full-flow filter	●
Hose rupture valve for arm cylinder	○
Hose rupture valve for boom cylinder	○
Hydraulic pilot type control levers	●
Low-temperature starting speed control	●
Main pump pressure and temperature sensor	●
Pilot control shut-off lever with neutral engine start system	●
Pilot filter	●
Suction filter	●
Swing drain filter	●
Swing parking brake	●
Travel parking brake	●
Two-speed travel system	●
Valve for extra piping	●
Variable relief valve for breaker and crusher	●
Work mode selector	●

CAB	ZX75US-7
AUX function lever (breaker)	●
AUX function lever (breaker / boom swing assist)	○
Auto control air conditioner	●
Blade lever with two-speed travel switch	●
Bluetooth® integrated radio	●
Control lever auto-lock	●
Defroster	●
Drink holder with hot and cool function	●
Electric horn	●
Engine shut-off switch	●
Equipped with reinforced glass windows	●
Evacuation hammer	●
Fire extinguisher mounting seat	●
Foot rest	●
Floor mat	●
Fluid-filled elastic mounts (4)	●
Front window washer (1 point)*2	●
Front window washer (2 points)*2	○
Hands-free calling device	●
Hot and cool box	●
Intermittent windshield wipers	●
LED room light	●
Lower front window one-touch lock (release lever)	●
Magazine rack	○
OPG top guard, Level II (ISO 10262: 1998) compliant	○
OPG front guard, Level II (ISO 10262: 1998) compliant	○
Pilot shut-off lever	●
Power outlet 12 V	●
Rain guard (without OPG front guard)*3	○
Rear tray	●
Retractable seat belt 3" (76 mm)	●
Rubber radio antenna	●
ROPS (ISO 12117-2: 2008) compliant cab	●
Seat: air suspension seat with heater	●
Seat adjustment part: backrest, armrest, height and angle, slide forward / back	●
Seat belt reminder	●
Smartphone holder	●
Stereo Speakers (2)	●
Sunscreen roller type (top window)	●
Sunscreen roller type (front window)	○
Tinted window glass (right side)	○
Transparent roof	●
USB power supply	●
Wide view wiper	○
Windows on front, upper and lower can be opened	●
Window (right side) guard pipe	●
8" monitor	●

●: Standard equipment ○: Optional equipment -: Not applicable

MONITOR SYSTEM	ZX75US-7
Alarms: overheat, engine warning, engine oil pressure, alternator, minimum fuel level, hydraulic filter restriction, air filter restriction, work mode, overload, etc	●
Alarm buzzers: overheat, engine oil pressure, overload, etc	●
Display of meters: water temperature, hour, fuel rate, clock, etc	●
Other displays: work mode, auto-idle, glow, rearview monitor, operating conditions, etc	●
35 language selection	●

LIGHTS	ZX75US-7
Additional 3 cab roof front LED lights	○
LED working lights (boom x 1, cab front x 1)	●
3 ambient LED lights (side and rear view camera)	○

UPPER STRUCTURE	ZX75US-7
AERIAL ANGLE (270-degree view camera system)	●
Auxiliary overload relief valve	●
Batteries 2 x 60 Ah	●
Fuel level float	●
Remote swing circle lubrication	●
Lockable tool box	●
Side view mirror (left side)	●
Undercover	●
2,568 lb (1,165 kg) counterweight	●
948 lb (430 kg) additional counterweight	○
2 way battery disconnect switch	●

UNDERCARRIAGE	ZX75US-7
Angle blade	○
Blade	●
Blade float	●
Reinforced track links with pin seals	●
Travel motor covers	●
4 tie down hooks	●
18" (450 mm) grouser shoe	○
18" (450 mm) pad crawler shoe	●
18" (450 mm) rubber shoe	○
24" (600 mm) grouser shoe	○

Standard and optional equipment may vary by country, so please consult your Hitachi Construction Machinery Americas authorized local dealer for details.

*1 Engine oil and hydraulic oil monitoring sensor.

*2 Front window washer (1 point) is only when equipped with standard wiper. Front window washer (2 points) is only when equipped with wide view wiper.

Hitachi Construction Machinery Americas reserves the right to change specifications at any time without prior notification. © 2024 All Rights Reserved

FRONT ATTACHMENTS	ZX75US-7
Arm 6' 11" (2.12 m)	●
Assist (2nd Auxiliary) piping	○
Dirt seal on all bucket pins	●
Extra piping	●
HN bushing	●
HRV cover	○
Reinforced resin thrust plate	●
WC (tungsten-carbide) thermal spraying	●
Quick coupler piping	○

MISCELLANEOUS	ZX75US-7
ConSite	○
Exclusive Global e-Service telematics	●
Standard tool kit	●

*3 Rain guard cannot be install when Cab front top guard and cab ceiling tower guard ISO (OPG) Level II conformance (ISO 10262: 1998) are installed.

HITACHI

Reliable Solutions



REPUTATIONS ARE **BUILT ON IT.**

A legacy built on quality products and service: this is our story. For more than 50 years, Hitachi Construction Machinery Americas has been the regional partner of Hitachi Construction Machinery Group, headquartered in Japan.

Well-respected in North America since the 1970s when Hitachi Construction Machinery Group led a prominent joint venture, Hitachi Construction Machinery Americas recently established a new facility in Newnan, GA. that is poised to support local customers for years to come.

With input from construction professionals on every continent, our machinery is manufactured at state-of-the-art facilities in Japan and exported for sale across the world.

Your local Hitachi Construction Machinery Americas dealer has the resources, expertise, and personnel to work with you, ensuring the best return on investment. Utilizing carefully designed programs and services in conjunction with extensive digital resources, Hitachi Construction Machinery Americas provides a focused approach to supporting you, your business, and the durable construction machinery that your operation relies upon.

Machines in this brochure may be representative of global products not sold in the North American market, and used for illustrative purposes only. Options may not be available in all markets. Before operating this machine (incl. satellite communication system) outside of its original country of sale, it may be necessary to make modifications to comply with local regulatory, safety, and legal requirements. Please do not export or operate this machine outside the country of its intended use until such compliance has been confirmed. Contact your dealer for more assistance with regional compliance.

